

Technical Data Sheet

pneum. Diaphragm Actuator

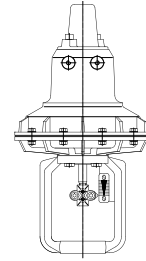

TD_811

Technical Data

Series	811
Diaphragm effective area	210 - 1440 cm ²
Stroke	10 - 120 mm
Control signal	6 bar max.
Materials	Body parts and diaphragm plates: seawater-proof aluminium alloy 3.2341 Spring tensioning screw, spindle bushing: 1.4104 Spindle: 1.4021(option: 1.4462) Yoke: 1.6220, free of non-ferrous metal Diaphragm: NBR, fabric-reinforced (moulded)
Operating temperature	-40 to + 80°C
Spindle bushing	Straight-through spindle with rolled surface, top and bottom guided in Polymer slide bearings. Pressure chamber with O-ring sealing.
Standard spring	Control range = 0,8 bar, for control function: air to open or air to close
Reinforced spring	Control range > 0,8 bar; for max. spring forces with control function: air to open

Functional description:

The actuators type 811 are pneumatic diaphragm actuators with spring return (fail safe) and are used to actuate linear valves. The actuator positions the valve plug in dependence of the signal pressure acting upon the actuator diaphragm, which in turn is controlled by a pneumatic or electro-pneumatic positioner. These actuators can be operated in the "Air to open" function or with the reverse action "Air to close".

- The central spring preload can be adjusted to optimum effect to the required actuating forces using the spring tensioning screw (1).
- A fabric-reinforced diaphragm ensures smooth conversion of the pneumatic application of pressure into the linear motion of the actuator spindle. The power diaphragm (3), supported by the diaphragm disc, is connected to the actuator spindle (4) and divides the actuator housing into pressure and spring chambers. If the force of the compressed air control signal exceeds the opposing spring force (2), the actuator spindle (4) moves and actuates the linear valve.
- The valve yoke (6) connects the actuator to the control valve, while the actuator spindle (4) is connected to the valve spindle via the coupling (5), which also acts as a stroke indicator, and is securely guided in the slide bearing and sealed with a sealing element.

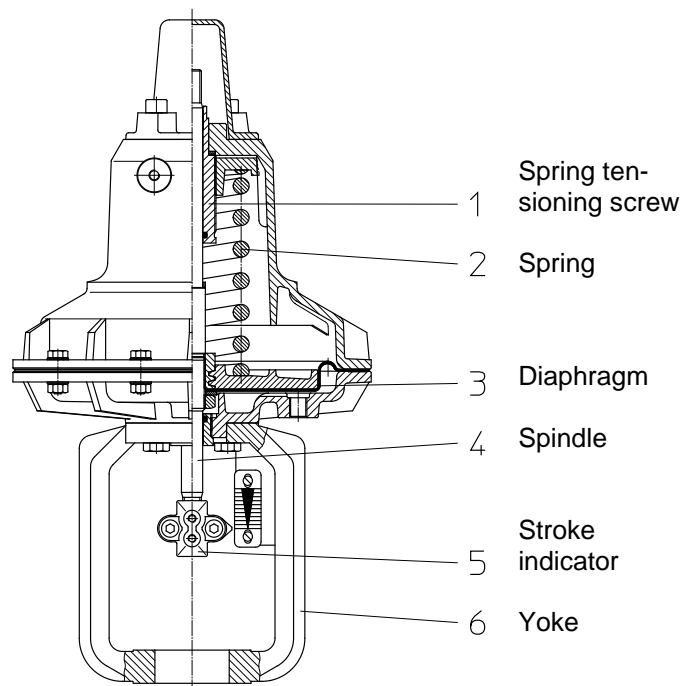

Technical Data Sheet

pneum. Diaphragm Actuator

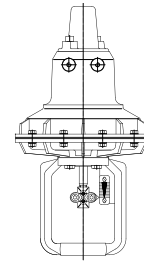

TD_811

Dimensions and weights

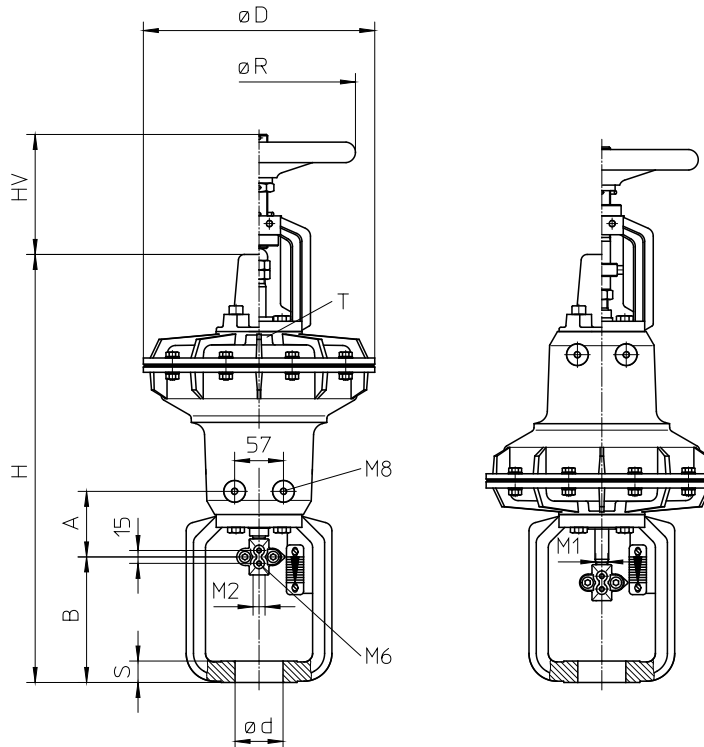

M2=Thread of particular valve spindle

Size	Diaph.-surf. (cm ²)	Order-No.	Weight (kg) handwheel w/o		Stroke	ØD	M1 actuator	Ød	S	B	A	H	HV	ØR	T female
U0	210	811-11..	6,6	8,2	10/20	230	M10	40	15	117	77	430	110	180	G ¼
		811-12..	7,0	8,6											
UI	320	811-22..	13,5	16,3	10/20	270	M14	48	20	127	82	495	135	225	G ¼
		811-23..	14,2	17,0	20/30										
UIII	720	811-33..	33,0	42,3	20/30	392	M14	56	25	151	155	722	197	320	G ½
		811-34..	33,2	42,5	30										
UV	1440	811-54..	79,0	99,0	30	530	M20x1,5	72	30	194	147	1006	295	400	2x G ½
		811-54..	85,0	105,0	45					60	187				
UV	1440	811-558..	100	120	100	530	M20x1,5	100	50	334	138	1134	295	400	2x G ½
UV	1440	811-559..	105	125	120	530	M20x1,5	100	50	344	128	1176	300	400	2x G ½

Technical Data Sheet

pneum. Diaphragm Actuator

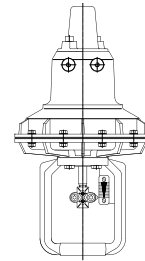

TD_811

Control forces and control ranges

Opening function (air to open - spring to close)

Size	Diaphragm surface (cm ²)	Order-No.	Spring-No.	Stroke (mm)	Control range adjustable (bar)		Control force (kN)
					from	to	
U0	210	811-1*11A	2054610	10	0,4-0,8	1,4-1,8	2,8
		811-1*31A		20	0,2-1,0	1,0-1,8	2,0
		811-1*11B	2054611	10	1,0-1,8	2,2-3,0	4,5
		811-1*31B		20	0,2-1,8	1,4-3,0	2,8
UI	320	811-2*12A	2054620	10	0,55-0,95	1,4-1,8	4,3
		811-2*32A		20	0,15-0,95	1,0-1,8	3,1
		811-2*32B	2054621	20	0,45-1,0	1,25-1,8	3,9
		811-2*42B		30	0,2-1,0	1,0-1,8	3,1
		811-2*12C	2054622	10	1,3-1,8	2,5-3,0	7,7
		811-2*32C		20	0,75-1,8	1,95-3,0	6,1
		811-2*42C		30	0,4-2,0	1,4-3,0	4,3
UIII	720	811-3*33A	2054630	20	0,45-1,0	1,45-2,0	10,3
		811-3*43A		30	0,2-1,0	1,2-2,0	8,4
		811-3*43B	2054631	30	0,45-1,0	1,25-1,8	8,8
		811-3*53B		45	0,2-1,0	1,0-1,8	7,0
		811-3*6 3C	2054632	60	0,2-1,0	0,8-1,6	5,6
		811-3*33D	2054633	20	1,35-1,9	2,45-3,0	17,3
		811-3*43D		30	1,4-2,2	2,2-3,0	15,5
		811-3*53D		45	1,0-2,2	1,8-3,0	12,7
811-3*63D	60	0,7-2,3		1,4-3,0	9,8		
UV	1440	811-5*45A	2054650	30	0,5-0,9	1,4-1,8	19,7
		811-5*55A		45	0,3-0,9	1,2-1,8	16,9
		811-5*65A		60	0,1-0,9	1,0-1,8	14,1
		811-5*65B	2054651	60	0,3-0,9	1,0-1,6	14,1
		811-5*75B		75	0,1-0,9	0,8-1,6	11,2
		811-5*85C	2054652	100	0,1-0,9	0,6-1,4	8,4
		811-5*95C		120	0,15-1,0	0,35-1,2	4,9
		811-5*45D	2054658	30	1,0-1,65	2,35-3,0	33,1
		811-5*55D		45	0,7-1,65	2,05-3,0	28,9
		811-5*65D		60	0,4-1,65	1,75-3,0	24,6
		811-5*75D		75	0,4-2,0	1,4-3,0	19,7
		811-5*85D	2054658 + 2054659	100	0,4-2,4	1,0-3,0	14,1
		811-5*95D		120	0,25-2,7	0,7-3,2	9,8
		811-5*45E	2054658 + 2054659	30	1,4-2,2	2,7-3,5	38,1
		811-5*55E		45	1,0-2,2	2,3-3,5	32,4
		811-5*65E		60	0,6-2,2	1,9-3,5	26,8
		811-5*75E		75	1,1-3,1	2,0-4,0	28,2
811-5*85E	100	0,4-3,1		1,34-4,0	18,3		
811-5*95E	120	0,4-4,1	1,1-4,6	15,5			

Caution: The actuator forces and spring ranges listed above are for actuator without valve at nominal stroke only.

Technical Data Sheet

pneum. Diaphragm Actuator

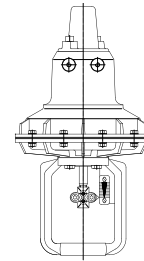

TD_811

Control forces and control ranges

Closing function (air to close - spring to open)

Spring relaxed

Size	Diaphragm surface (cm ²)	Order-No.	Spring-No.	Stroke (mm)	Control range (bar)	Control force kN depending on control pressure (bar)					
						1,4	2,0	2,5	3,0	4,5	6,0
U0	210	811-1*11A	2054610	10	0,4-0,8	0,8	2,0	3,0	4,1	7,2	10,2
		811-1*31A		20	0,2-1,0	0,4	1,6	2,6	3,7	6,7	9,8
		811-1*11B	2054611	10	1,0-1,8	--	--	1,0	2,0	5,1	8,2
		811-1*31B		20	0,2-1,8	--	--	1,0	2,0	5,1	8,2
UI	320	811-2*12A	2054620	10	0,55-0,95	0,7	2,6	4,2	5,8	10,5	15,2
		811-2*32A		20	0,15-0,95	0,7	2,6	4,2	5,8	10,5	15,2
		811-2*32B	2054621	20	0,45-1,0	0,6	2,5	4,0	5,6	10,3	15,0
		811-2*42B		30	0,2-1,0	0,6	2,5	4,0	5,6	10,3	15,0
		811-2*12C	2054622	10	1,3-1,8	--	--	1,5	3,1	7,8	12,5
		811-2*32C		20	0,75-1,8	--	--	1,5	3,1	7,8	12,5
		811-2*42C		30	0,4-2,0	--	--	0,9	2,5	7,2	11,9
UIII	720	811-3*33A	2054630	20	0,45-1,0	1,4	5,6	9,1	12,7	23,2	33,8
		811-3*43A		30	0,2-1,0	1,4	5,6	9,1	12,7	23,2	33,8
		811-3*43B	2054631	30	0,45-1,0	1,4	5,6	9,1	12,7	23,2	33,8
		811-3*53B		45	0,2-1,0	1,4	5,6	9,1	12,7	23,2	33,8
		811-3*63C	2054632	60	0,2-1,0	1,4	5,6	9,1	12,7	23,2	33,8
		811-3*33D	2054633	20	1,35-1,9	--	--	2,8	6,3	16,9	27,5
		811-3*43D		30	1,4-2,2	--	--	0,7	4,2	14,8	25,4
		811-3*53D		45	1,0-2,2	--	--	0,7	4,2	14,8	25,4
811-3*63D	60	0,7-2,3		--	--	--	3,5	14,1	24,6		
UV	1440	811-5*45A	2054650	30	0,5-0,9	4,2	12,7	19,7	26,8	47,9	69,1
		811-5*55A		45	0,3-0,9	4,2	12,7	19,7	26,8	47,9	69,1
		811-5*65A		60	0,1-0,9	4,2	12,7	19,7	26,8	47,9	69,1
		811-5*65B	2054651	60	0,3-0,9	4,2	12,7	19,7	26,8	47,9	69,1
		811-5*75B		75	0,1-0,9	4,2	12,7	19,7	26,8	47,9	69,1
		811-5*85C	2054652	100	0,1-0,9	4,2	12,7	19,7	26,8	47,9	69,1
		811-5*95C		120	0,15-1,0	2,8	11,2	18,3	25,4	46,5	67,7
		811-5*45D	2054658	30	1,0-1,65	7,7	16,2	23,2	30,3	51,5	72,6
		811-5*55D		45	0,7-1,65	7,7	16,2	23,2	30,3	51,5	72,6
		811-5*65D		60	0,4-1,65	7,7	16,2	23,2	30,3	51,5	72,6
		811-5*75D		75	0,4-2,0	--	--	4,2	11,2	32,4	53,6
		811-5*85D		100	0,4-2,4	--	--	--	5,6	26,8	47,9
		811-5*95D	120	0,25-2,7	--	--	--	1,4	22,5	43,7	
		811-5*45E	2054658 + 2054659	30	0,6-1,4	--	5,6	12,7	19,7	40,9	62,0
		811-5*55E		45	0,6-1,8	--	--	7,0	14,1	35,2	56,4
		811-5*65E		60	0,6-2,2	--	--	1,4	8,4	29,6	50,8
		811-5*75E		75	0,4-2,45	--	--	--	4,9	26,1	47,2
		811-5*85E		100	0,4-3,1	--	--	--	--	16,9	38,1
		811-5*95E	120	0,4-4,1	--	--	--	--	2,8	23,9	

Caution: The actuator forces and spring ranges listed above are for actuator without valve at nominal stroke only.

Technical Data Sheet

pneum. Diaphragm Actuator

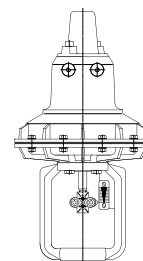

TD_811

Type code

811 - 2 2 3 2A - O - HV

Series

Actuator size

- 1 U0 diaphragm area 210 cm²
- 2 UI diaphragm area 320 cm²
- 3 UIII diaphragm area 720 cm²
- 5 UV diaphragm area 1440 cm²

Yoke (ø = mounting in mm)

0	1	2	3	4	5	9
w/o	ø40	ø48	ø56	ø72	ø100	Sonder

Stroke

1	3	4	5	6
10 mm	20 mm	30 mm	45 mm	60 mm
7	8	9	0	
75 mm	100 mm	120 mm	Sonder	

Spring No.

for U0:	1A	1B			
	2054610	2054611			
for UI:	2A	2B	2C		
	2054620	2054621	2054622		
for UIII:	3A	3B	3C	3D	
	2054630	2054631	2054632	2054633	
for UV:	5A	5B	5C	5D	5E
	2054650	2054651	2054652	2054658	2054658+2054659

Function

- O** Stem extended by spring (normally closed)
- S** Stem retracted by spring (normally open)

Additional equipment

- BE** Instrument air purge of the spring chamber
- BH** HV yoke for accessories
- EX** Explosion-proof version
- H** Cover
- HB** Stroke limiter
- HV** Handwheel
- SB** Stem protection bellows
- VA** Screws stainless steel
- Z** Peripheral bolting to ASME

Example of type designation 811-2232A-O HV VA

Diaphragm actuator 811 – actuator size UI – mounting diameter 48 mm – stroke 20 mm – spring 2054620 – function normally closed – additional equipment handwheel + screws stainless steel.