

Technical Data Sheet Control Valve Series 190

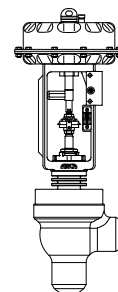

TD_190

General Data

Series	190 Single seated control valve in forged design globe and angle style
Nominal size DN / NPS	25 - 65 / 1" - 2 1/2"
Nominal pressure PN / ANSI	100 - 400 / Class 600 - 2500
Connections	butt-weld ends acc. to DIN EN 12627 butt-weld ends acc. to ASME B16.25 socket weld ends acc. to DIN EN 12760* socket weld ends and threaded connections acc. to ASME B16.11**
Characteristic	equal percentage or linear
Rangeability	50:1
Plug guide	stem guided
Seat leakage	metal sealing: IEC 60534-4 leakage class IV (0,01% of Kvs value); optional: leakage class V
Heating jacket (optional)	connections: DN 15 PN 40 (1/2" ANSI 300) flanged or butt-weld ends

*: only as of nominal size max. DN 50 PN 100

** : only as of nominal size max. 2" class 1500

Materials

	EN	for temperatures	ASTM	for temperatures
Body material	1.0460 C 22.8 P250GH	-10 to 400°C	A105	-29°C to 425°C
	1.5415 16Mo3	-10 to 530°C	---	---
	1.7383 11CrMo9-10	-10 to 600°C	A182 F12 Cl.3	-29°C to 650°C
	1.4903 X10CrMoVNb 9-2	-10 to 600°C	A182 F91	-29°C to 650°C
Bonnet material	same as body material; bonnet 1.7383 (11CrMo9-10) on 1.5415 (16Mo3) body			

Valve trim materials						
Material no.	Parabolic plug P1	Seat for parabolic plug	Perforated plug L1	Seat for perforated plug	Seat seal	Max. medium-temperature
1	1.4122	1.4021	-	1.4021 nitrided	metal	400°C
2	1.4571	1.4571	1.4571	1.4571 nitrided	metal	500°C*
3	1.4112 hardened	1.4112 hardened	1.4112	1.4112 hardened	metal	400°C
4	1.4922	1.4922	1.4922	1.4922 nitrided	metal	500°C
5	1.4922	1.4922	1.4922	1.4922 hardened	metal	600°C

* with parabolic plug P1 up to 650°C

Technical Data Sheet Control Valve Series 190

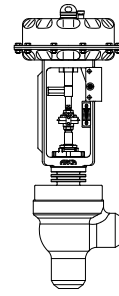

TD_190

Stem sealing

Seal type	Packing (pos. A)	Wiper ring (pos. D)	Medium-temperature	Bonnet flange
adjustable	reinforced graphite / Inconel	NBR	-29 ~ 400°C	cooling fins
adjustable	pure graphite	NBR	-29 ~ 565°C	cooling fins
adjustable	graphite / PTFE braided	NBR	-29 ~ 250°C	cooling fins

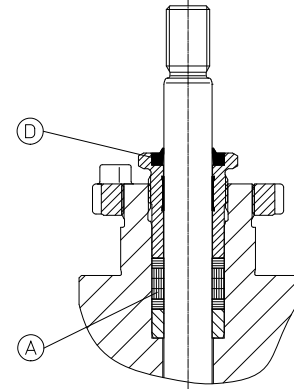

Weight and dimensions

Series 190 globe and angle style

Dimensions (in mm) for valves with butt-weld ends acc. to DIN EN ISO 9692-1 / DIN EN 12627 as well as acc. to ASME B16.25 with socket weld ends acc. to DIN EN 12760 with socket weld ends or threaded connections acc. to ASME B16.11						
	DN ANSI NPS	25 1"	32 1 1/4"	40 1 1/2"	50 2"	65 2 1/2"
Series 190 globe style	VBL	340				
	VU	43				
	VH	233				
Series 190 angle style	VR	145				
	VU	145				
	VH	158				
Actuator type 812	ØA	MFI-30	270			
		MFIII-30	400			
		MFIII(v)-30	400			
	AH	MFI-30	404			
		MFIII-30	489			
		MFIII(v)-30	551			
	AHV	MFI-30	551			
		MFIII-30	651			
		MFIII(v)-30	814			
	ØAH	MFI-30	220			
		MFIII-30	335			
		MFIII(v)-30	335			
valve + actuator weight* ca. kg	MFI	49				
	MFIII	75				
	MFIII(v)	77				
B		200				
Actuator type 811	ØA	530				
	AH	1006				
	AHV	1301				
	ØAH	400				
	valve + actuator weight* ca. kg	118				
	B		250			

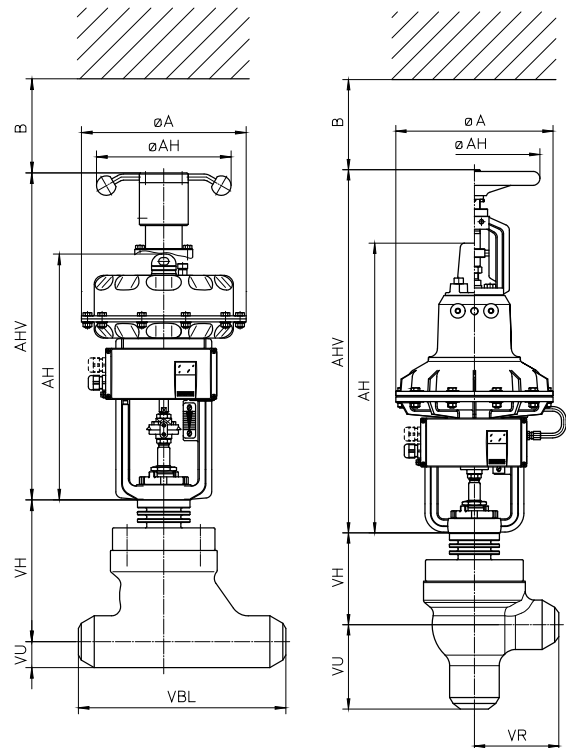

Series 190
globe style
actuator type 812

Series 190
angle style
actuator type 811

* Weight: Valve (with DEK3 cooling fins) + actuator without handwheel

Technical Data Sheet Control Valve Series 190

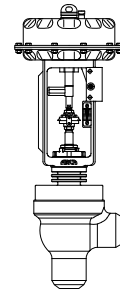

TD_190

Series 190 pressure / temperature diagram acc. to EN 12516-1

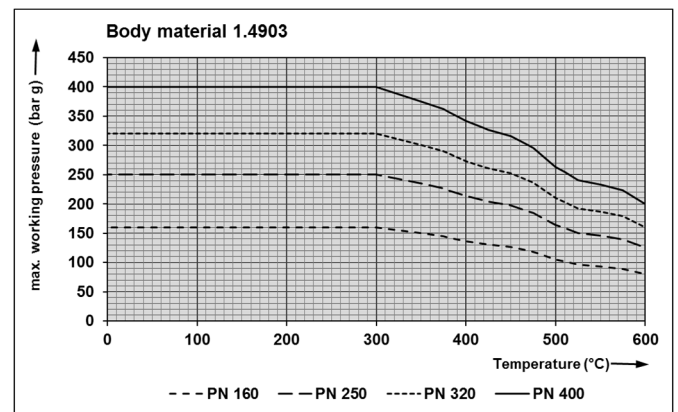
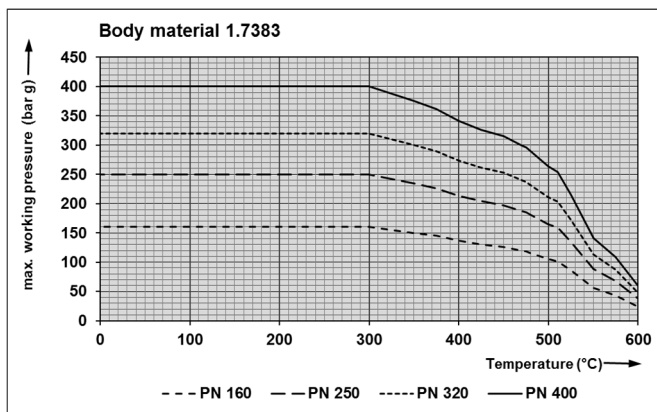
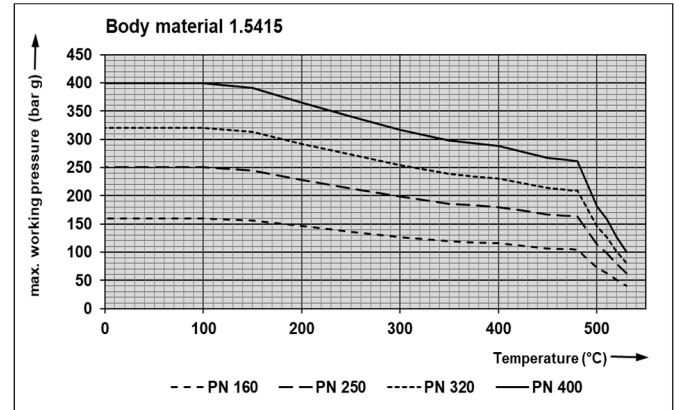
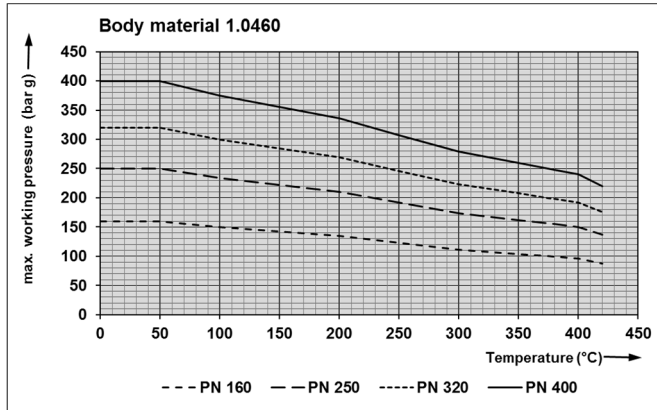

Butt-weld ends acc. to DIN EN 12627

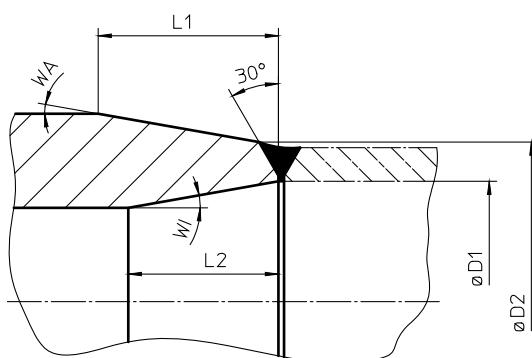

DN	PN	butt-weld ends	pipe AD	ØD1	ØD2	L1	WA	L2	WI
25	100	SED100	33,7	28,5	35	>48	10°	>33,6	0°
	160	SED160	33,7	27,9	35	>48	10°	>33,6	0°
	250	SED250	33,7	26,5	35	>48	10°	>33,6	0°
	320	SED320	33,7	23,7	35	>48	10°	>33,6	0°
32	100	SED100	42,4	28,2	44	>48	10°	>33,6	0°
	400	SED400	42,4	28,2	44	>48	10°	>33,6	0°
40	100	SED100	48,3	41,9	50	>48	10°	>33,6	0°
	160	SED160	48,3	41,1	50	>48	10°	>33,6	0°
	250	SED250	48,3	38,3	50	>48	10°	>33,6	0°
	320	SED320	48,3	35,7	50	>48	10°	>33,6	0°
50	100	SED100	60,3	53,1	61,5	>48	10°	>33,6	0°
	160	SED160	60,3	52,3	61,5	>48	10°	>33,6	0°
	250	SED250	60,3	47,7	61,5	>48	10°	>33,6	0°
	320	SED320	63,5	47,5	65	>48	10°	>33,6	0°
65	400	SED400	76,1	51,1	77	>48	5°	>33,6	0°
	100	SED100	76,1	68,1	77	>48	5°	>33,6	0°
	160	SED160	76,1	66,1	77	>48	5°	>33,6	0°
	250	SED250	76,1	60,1	77	>48	5°	>33,6	0°

Technical Data Sheet Control Valve Series 190

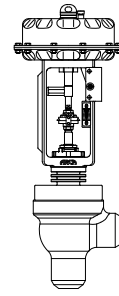

TD_190

Series 190 pressure / temperature diagram acc. to ASME B16.34

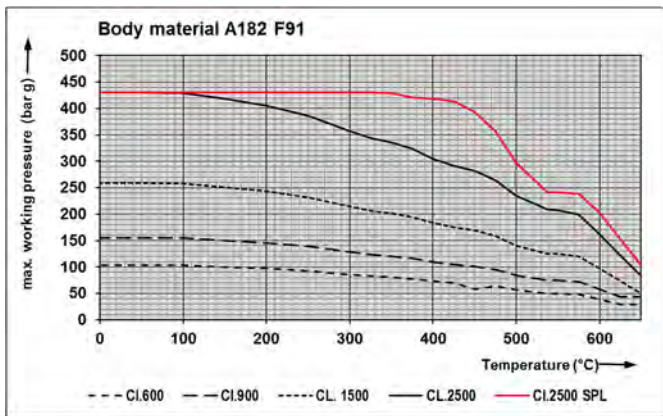
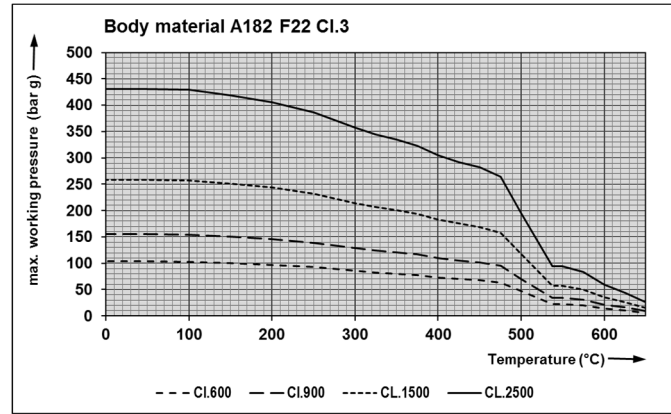
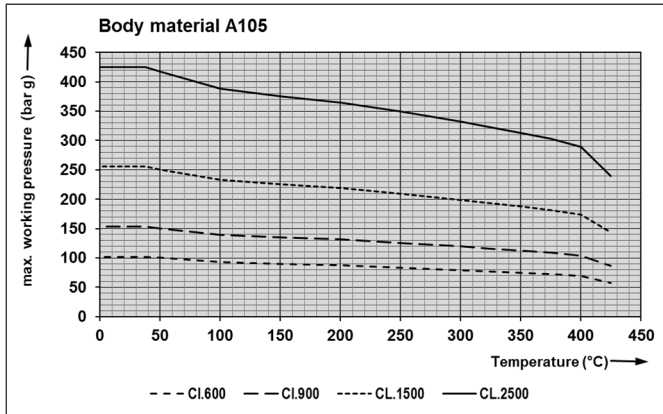

Butt-weld ends acc. to ASME B16.25

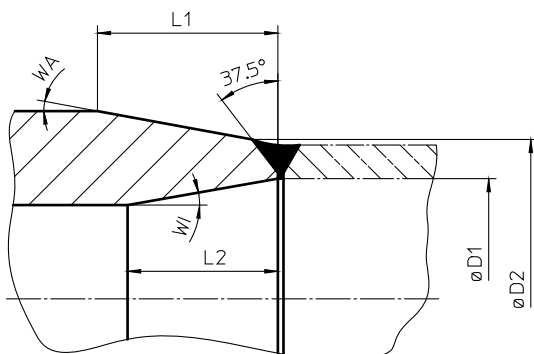

NPS	Sched.	butt-weld ends	pipe AD	$\varnothing D1$	$\varnothing D2$	L1	WA	L2	WI
1"	40	SEA40	33,7	26,94	35	>48	10°	>33,6	0°
	80	SEA80	33,7	24,6	35	>48	10°	>33,6	0°
	160	SEA160	33,7	21	35	>48	10°	>33,6	0°
	XXS	SEAXXS	33,7	15,52	35	>48	10°	>33,6	0°
1 1/4"	40	SEA40	42,2	35,08	44	>48	10°	>33,6	0°
	80	SEA80	42,2	32,5	44	>48	10°	>33,6	0°
	160	SEA160	42,2	29,5	44	>48	10°	>33,6	0°
	XXS	SEAXXS	42,2	22,8	44	>48	10°	>33,6	0°
1 1/2"	40	SEA40	48,3	40,94	50	>48	10°	>33,6	0°
	80	SEA80	48,3	38,14	50	>48	10°	>33,6	0°
	160	SEA160	48,3	34,02	50	>48	10°	>33,6	0°
	XXS	SEAXXS	48,3	28	50	>48	10°	>33,6	0°
2"	40	SEA40	60,3	52,48	61,5	>48	10°	>33,6	0°
	80	SEA80	60,3	49,22	61,5	>48	10°	>33,6	0°
	160	SEA160	60,3	42,82	61,5	>48	10°	>33,6	0°
	XXS	SEAXXS	60,3	38,16	61,5	>48	10°	>33,6	0°
2 1/2"	40	SEA40	73	62,68	75	>48	5,5°	>33,6	0°
	80	SEA80	73	58,98	75	>48	5,5°	>33,6	0°
	160	SEA160	73	53,94	75	>48	5,5°	>33,6	0°
	XXS	SEAXXS	73	44,96	75	>48	5,5°	>33,6	0°

Technical Data Sheet

Control Valve Series 190

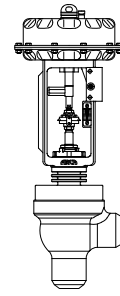

TD_190

Max. shut-off differential pressure in bar

Series 190 PN100 - PN400 as well as ANSI Class 600 - ANSI Class 2500																				
Valid for valves w/o pressure balancing with graphite packing and for leakage class IV																				
Flow to open (FTO) (at P ₂ = 0 bar g)																				
Actuator series 812										Air to open spring to close No. of springs				Air to close spring to open No. of springs						
DN	Stroke (mm)	Actuator size	P1		L1 lin		L1 =%		Seat-Ø (mm)	3	6	9	12	Min. air supply (bar)						
			Kv	Cv	Kv	Cv	Kv	Cv		bar	bar	bar	bar	3.0	4.5	6.0	4.5	6.0		
25 32	20	MFI-30 (320 cm ²) 812-234..	0,1	0,12	-	-	-	-	4	33	130	-	-	106	251	396	130	275		
			0,16	0,19	-	-	-	-	4	33	130	-	-	106	251	396	130	275		
			0,25	0,29	-	-	-	-	5	33	130	-	-	106	251	396	130	275		
			0,4	0,46	-	-	-	-	5	33	130	-	-	106	251	396	130	275		
			0,63	0,73	-	-	-	-	5	33	130	-	-	106	251	396	130	275		
			1	1,16	-	-	-	-	8	33	130	-	-	106	251	396	130	275		
			1,6	1,9	-	-	-	-	10	33	130	-	-	106	251	396	130	275		
			2,5	2,9	-	-	-	-	12	33	130	-	-	106	251	396	130	275		
			4	4,6	4	4,6	4	4,6	16	33	130	-	-	106	251	396	130	275		
		6,3	7,3	6,3	7,3	6,3	7,3	20	22	119	-	-	95	240	385	119	264			
		10	11,6	10	11,6	8,5	9,9	25	12	74	-	-	59	152	244	74	167			
		1" 1 1/4"	20	MFIII-30 (720 cm ²) 812-334..	0,1	0,12	-	-	-	-	4	148	372	400	-	317	-	-	372	-
					0,16	0,19	-	-	-	-	4	148	372	400	-	317	-	-	372	-
					0,25	0,29	-	-	-	-	5	148	372	400	-	317	-	-	372	-
					0,4	0,46	-	-	-	-	5	148	372	400	-	317	-	-	372	-
					0,63	0,73	-	-	-	-	5	148	372	400	-	317	-	-	372	-
					1	1,16	-	-	-	-	8	148	372	400	-	317	-	-	372	-
					1,6	1,9	-	-	-	-	10	148	372	400	-	317	-	-	372	-
2,5	2,9				-	-	-	-	12	148	372	400	-	317	-	-	372	-		
4	4,6				4	4,6	4	4,6	16	148	372	400	-	317	-	-	372	-		
6,3	7,3	6,3	7,3	6,3	7,3	20	137	361	400	-	306	-	-	361	-					
10	11,6	10	11,6	8,5	9,9	25	85	229	290	360	194	400	-	229	400					
40	20	MFI-30 (320 cm ²) 812-234..	1	1,16	-	-	-	-	8	33	130	-	-	106	251	396	130	275		
			1,6	1,9	-	-	-	-	10	33	130	-	-	106	251	396	130	275		
			2,5	2,9	-	-	-	-	12	33	130	-	-	106	251	396	130	275		
			4	4,6	4	4,6	4	4,6	16	33	130	-	-	106	251	396	130	275		
			6,3	7,3	6,3	7,3	6,3	7,3	20	22	119	-	-	95	240	385	119	264		
			10	11,6	10	11,6	8,5	9,9	25	12	74	-	-	59	152	244	74	167		
			16	19	12	14	10	11,6	30	7	50	-	-	39	104	168	50	115		
			25	29	21	24	18	21	37	3	32	-	-	24	67	109	32	74		
			1 1/2"	20	MFIII-30 (720 cm ²) 812-334..	1	1,16	-	-	-	-	8	148	372	400	-	317	-	-	372
		1,6				1,9	-	-	-	-	10	148	372	400	-	317	-	-	372	-
		2,5				2,9	-	-	-	-	12	148	372	400	-	317	-	-	372	-
		4				4,6	4	4,6	4	4,6	16	148	372	400	-	317	-	-	372	-
		6,3				7,3	6,3	7,3	6,3	7,3	20	137	361	400	-	306	-	-	361	-
		10				11,6	10	11,6	8,5	9,9	25	85	229	290	360	194	400	-	229	400
		16				19	12	14	10	11,6	30	58	158	200	249	133	279	400	158	303
		25				29	21	24	18	21	37	37	102	130	162	86	182	277	102	198

Please pay attention to the pressure / temperature rating of the valve body!

For other valve/packing versions, refer to ARCA-VENA valve sizing.

Technical Data Sheet Control Valve Series 190

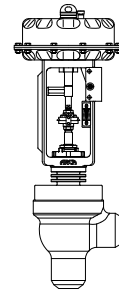

TD_190

Max. shut-off differential pressure in bar

Series 190 PN100 - PN400 as well as ANSI Class 600 - ANSI Class 2500																		
Valid for valves w/o pressure balancing with graphite packing and for leakage class IV																		
Flow to open (FTO) (at P ₂ = 0 bar g)																		
Actuator series 812										Air to open spring to close No. of springs				Air to close spring to open No. of springs				
										3	6	9	12	3	3	3	6	6
DN	Stroke (mm)	Actuator size	P1		L1 lin		L1 =%		Seat-Ø (mm)					Min. air supply (bar)				
			Kv	Cv	Kv	Cv	Kv	Cv		bar	bar	bar	bar	3.0	4.5	6.0	4.5	6.0
50	20	MFI-30 (320 cm ²) 812-234..	4	4,6	4	4,6	4	4,6	16	33	130	-	-	106	251	396	130	275
			6,3	7,3	6,3	7,3	6,3	7,3	20	22	119	-	-	95	240	385	119	264
			10	11,6	10	11,6	8,5	9,9	25	12	74	-	-	59	152	244	74	167
			16	19	12	14	10	11,6	30	7	50	-	-	39	104	168	50	115
			25	29	21	24	18	21	37	3	32	-	-	24	67	109	32	74
65		MFIII-30 (720 cm ²) 812-334..	4	4,6	4	4,6	4	4,6	16	148	372	400	-	317	-	-	372	-
			6,3	7,3	6,3	7,3	6,3	7,3	20	137	361	400	-	306	-	-	361	-
			10	11,6	10	11,6	8,5	9,9	25	85	229	290	360	194	400	-	229	400
			16	19	12	14	10	11,6	30	58	158	200	249	133	279	400	158	303
			25	29	21	24	18	21	37	37	102	130	162	86	182	277	102	198
2"	MFIII-30(v) (720 cm ²) 812-336..	4	4,6	4	4,6	4	4,6	16	205	400	-	-	372	-	-	400	-	
		6,3	7,3	6,3	7,3	6,3	7,3	20	194	400	-	-	252	-	-	400	-	
		10	11,6	10	11,6	8,5	9,9	25	122	294	364	400	159	368	-	299	-	
		16	19	12	14	10	11,6	30	83	203	251	306	109	254	399	206	351	
		25	29	21	24	18	21	37	53	132	164	200	70	166	261	134	229	
2 1/2"			4	4,6	4	4,6	4	4,6	16	205	400	-	-	372	-	-	400	-
			6,3	7,3	6,3	7,3	6,3	7,3	20	194	400	-	-	252	-	-	400	-
			10	11,6	10	11,6	8,5	9,9	25	122	294	364	400	159	368	-	299	-
			16	19	12	14	10	11,6	30	83	203	251	306	109	254	399	206	351
			25	29	21	24	18	21	37	53	132	164	200	70	166	261	134	229
			40	46	35	41	20	23	48	30	77	96	117	40	97	154	78	135

Max. shut-off differential pressure in bar

Series 190 PN100 - PN400 as well as ANSI Class 600 - ANSI Class 2500																		
Valid for valves w/o pressure balancing with graphite packing and for leakage class IV																		
Flow to open (FTO) (at P ₂ = 0 bar g)																		
Actuator series 811										Air to open spring to close								
										811.41		811.44		811.41		811.44		
Control range (bar)										1,5-1,8		2,55-3,0		1,0- 1,3		1,75 - 2,2		
DN	Stroke (mm)	Actuator size	P1		L1 lin		L1 =%		Seat-Ø (mm)			Min. air supply (bar)						
			Kv	Cv	Kv	Cv	Kv	Cv		bar	bar	3.0	4.5	6.0	4.5	6.0		
50 65	20	UV-60 (811.41)	10	11,6	10	11,6	8,5	9,9	25	368	-	400	-	-	-	-		
			16	19	12	14	10	11,6	30	254	400	293	-	-	400	-		
			25	29	21	24	18	21	37	166	299	191	382	-	268	400		
2" 2 1/2"		UV-60v (811.44)	40	46	35	41	20	23	48	97	177	112	226	339	158	271		

Please pay attention to the pressure / temperature rating of the valve body!

For other valve/packing versions, refer to ARCA-VENA valve sizing.



Technical Data Sheet

Control Valve Series 190

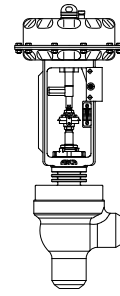

TD_190

Model code series 190

0. Operating data		8. Body materials ¹⁾		18. Seat retainer ¹⁾	
Medium:		2	1.0460 / A105	0	Standard
Temperature:	°C	4	1.5415	1	LN (Low Noise) not controlled
Pressure P ₁ :	bar abs.	5	1.7383 / A182 F12 Cl.3	2	LN (Low Noise) controlled
Pressure P ₂ :	bar abs.	6	1.4903 / A182 F91	19. Perforated cage	
P Design	bar g	9	Others (acc. to spec.)	0	w/o
T Design	°C	9. Stem guide		20. Stem seal ¹⁾	
1. Series		0	Stem guided (Standard)	3	Reinforced graphite / Inconel
19	High pressure control valve	10. KVs Value		4	Pure graphite
2. Top flange		XXX	acc. to table	5	Graphite / PTFE braided
3	Cooling fins	11. Flow characteristic		9	Others (acc. to spec.)
3. Plug design		g	=%	21. Special designs	
P1, P3 ¹⁾	Parabolic plug (1-step, 3-step)	l	linear	0	Standard
L1, L2 ¹⁾	Perforated plug (1-step, 2-step)	12. Plug materials ¹⁾		1	AD2000
4. Design		1	1.4122	2	ASME B16.34
D	Globe style	2	1.4571	3	TRD 110 Gr.1
E	Angle style	3	1.4112	4	TRD 110 Gr.2
5. Valve size		4	1.4922	7	NACE
25	DN 25 / ANSI 1"	9	Others (acc. to spec.)	9	Others (acc. to spec.)
32	DN 32 / ANSI 1 1/4"	13. Plug wear / tear protection ¹⁾		22. Material certificates (pressure retaining parts)	
40	DN 40 / ANSI 1 1/2"	0	w/o	0	w/o
50	DN 50 / ANSI 2"	1	Nitrided	1	EN 10204-2.1
65	DN 65 / ANSI 2 1/2"	2	Hardened	2	EN 10204-3.1
6. Pressure rating (PN)		3	Sealing surface stellite	3	EN 10204-3.2
100	PN 100	4	Completely stellite	9	Others (acc. to spec.)
160	PN 160	5	Colsterised	23. Final inspections	
250	PN 250	9	Others (acc. to spec.)	0	None
400	PN 400	14. Pressure balancing		1	EN 10204-2.1
600	ANSI B16.34 Class 600	0	w/o	2	EN 10204-2.2
900	ANSI B16.34 Class 900	15. Seat materials ¹⁾		3	EN 10204-3.1
1500	ANSI B16.34 Class 1500	1	1.4021	4	EN 10204-3.2
2500	ANSI B16.34 Class 2500	2	1.4571	9	Others (acc. to spec.)
2500SP	ANSI B16.34 Special Class 2500	3	1.4112	*) with P3 and L2 reduced Kvs-values and limited seat diameters.	
7. Connections		4	1.4922		
SED100	Butt-weld for pipe PN 100	9	Others (acc. to spec.)		
SED160	Butt-weld for pipe PN 160	16. Seat wear / tear protection ¹⁾			
SED250	Butt-weld for pipe PN 250	0	w/o		
SED320	Butt-weld for pipe PN 320	1	nitrided		
SED400	Butt-weld for pipe PN 400	2	hardened		
SEA40	Butt-weld for pipe Sched.40	3	Sealing surface stellite		
SEA80	Butt-weld for pipe Sched.80	4	Completely stellite		
SEA160	Butt-weld for pipe Sched.160	5	Colsterised		
SEAXXS	Butt-weld for pipe Sched. XXS	9	Others (acc. to spec.)		
SMD	Socket weld acc. to EN 12760	17. Seat / plug sealing			
SMA	Socket weld acc. to ASME B16.11	0	Leakage class IV metal to metal		
GA	Threaded connections acc. to ASME B16.11				
VE(Ø / t)	Butt-weld with spool pieces (Ø / wall thickness)			1	Leakage class V

1) In accordance with customer specification, otherwise selected by the manufacturer in accordance with customer process data (medium, pressure, temperature, etc.).

Example:

19 - 3 - L1 - E - 50 - 1500 - SEA160 - 6 *Position 1-8 / basic data*

Series 193 - with cooling fins - 1-step perf. plug - angle style DN 50 / 2" - Class 1500 - butt-weld ends for pipeSch.160 - body material A182 F91

0 - 18 - g - 4 - 0 - 0 - 4 - 1 - 0 - 0 - 0 - 3 *Position 9-20 / valve trims*

Stem guided - KVs 18 (Cv 21) - equal perc. - plug material 1.4922 - no wear/tear protection - not balanced - seat made of 1.4922 - seat ring nitrided - leakage class IV - standard cage retainer - no seat retainer - stem seal reinforced graphite/Inconel adjustable

2 - 3 - 3 *Position 21-23 / special designs / inspections*

Design acc. to B16.34 - material inspection acc. to EN 10204 3.1 - final inspection acc. to EN 10204 3.1

Technical Data Sheet Control Valve Series 190

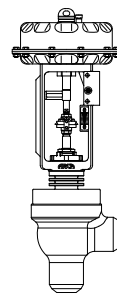

TD_190

